

# A+P-NAT at CPE

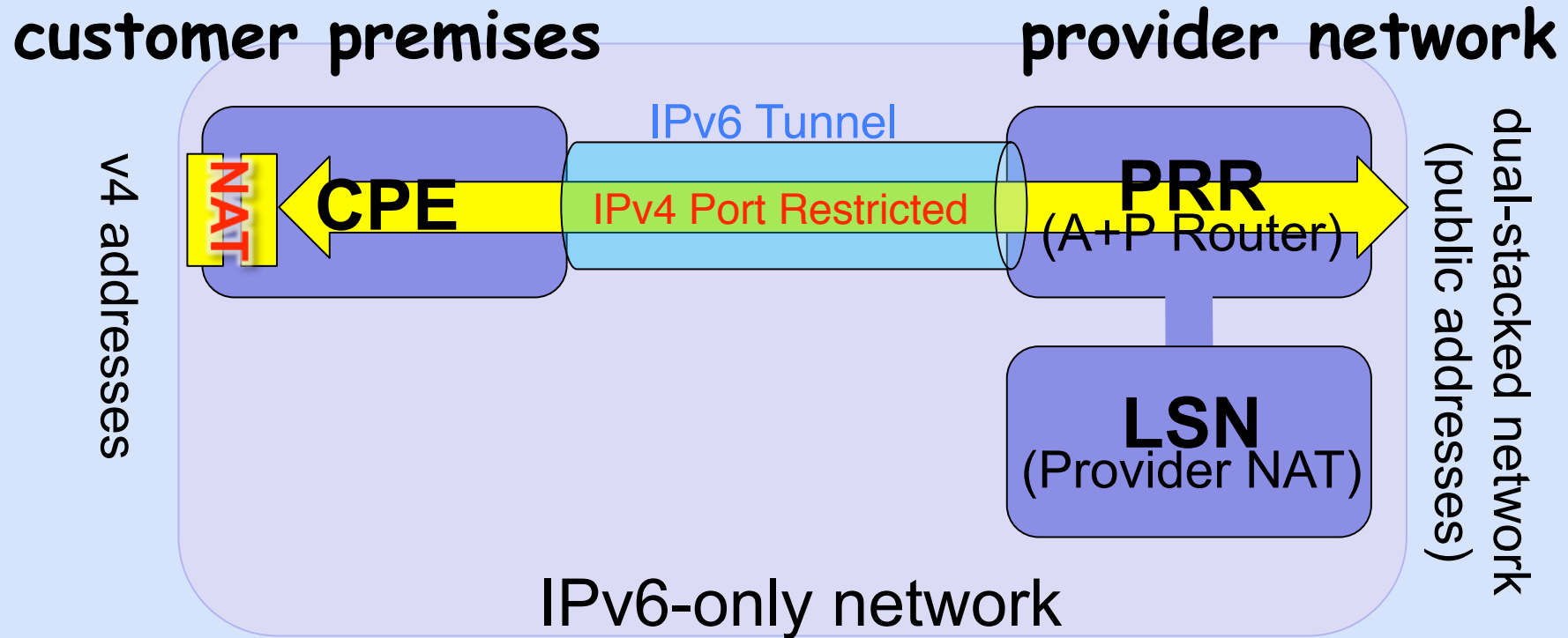

- Un-NATted end-to-end to CPE
- CPE NATs to connect to IPv4 hosts
- APR encap/decaps only (LSN bypassed)!

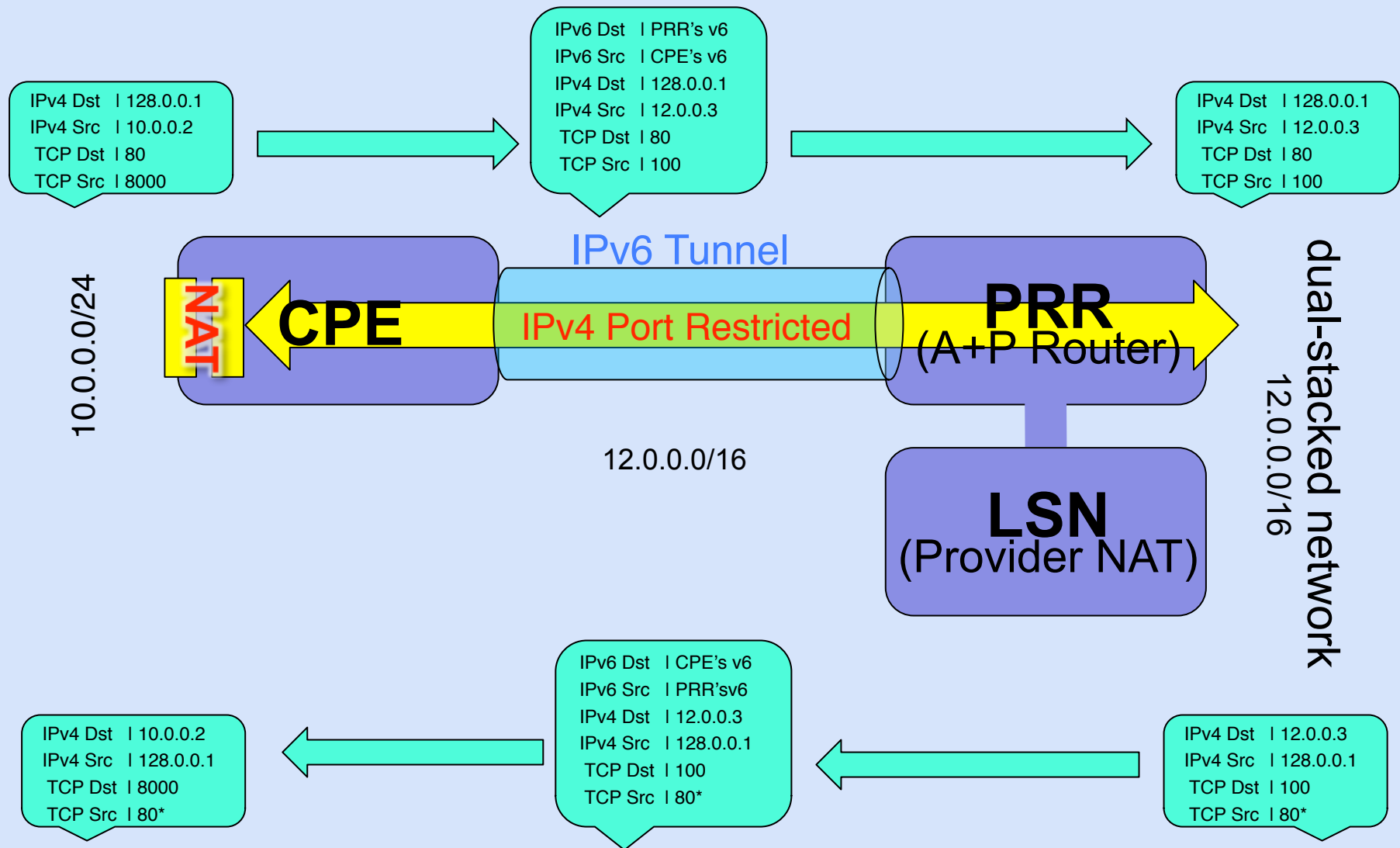

80\* - web sites usually port shift the replies

# DS-Lite NAT at LSN

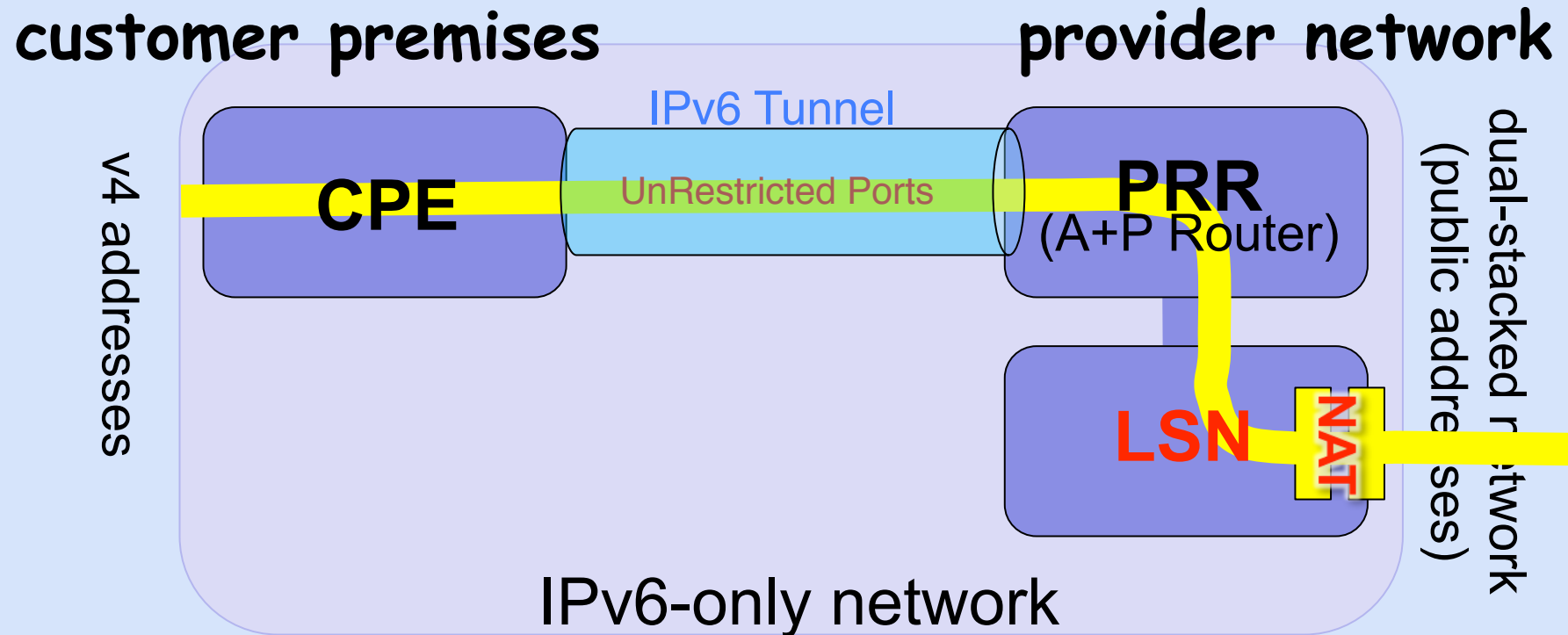

- Legacy-style DS-Lite, NAT done at LSN
- However, customer could have chosen where NAT is done!

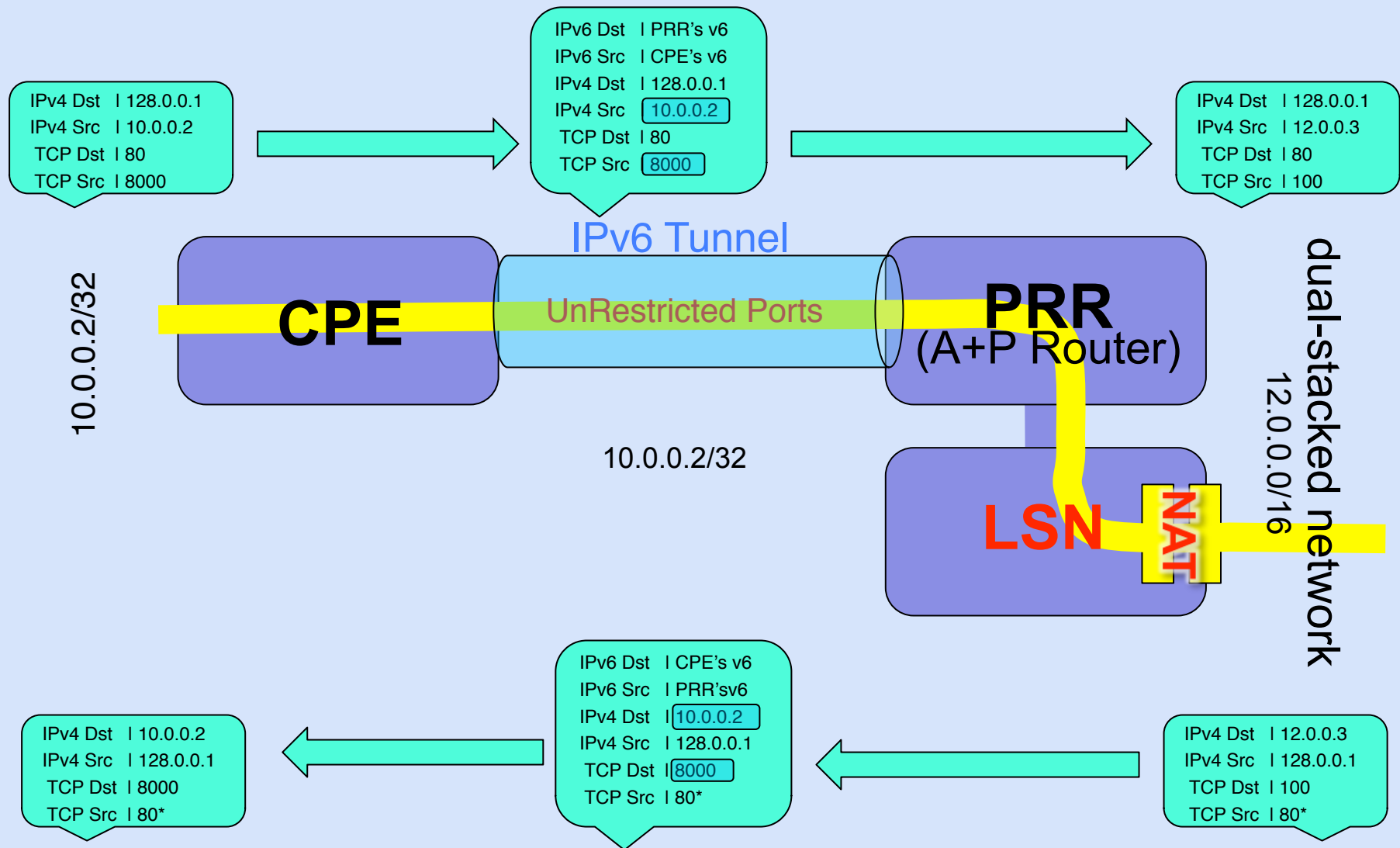

80\* - web sites usually port shift the replies